

# Simulation & Animation

THUAS Delft, The Netherlands  
P.J. van Duijsen

*Caspoc*

[www.caspoc.com](http://www.caspoc.com)

November 22 , 2024

## Simulation &amp; Animation

- 1 Introduction
- 2 Methodology
- 3 Online Tools
- 4 Online Simulation
- 5 Power Electronics Simulation
- 6 Virtual Labs

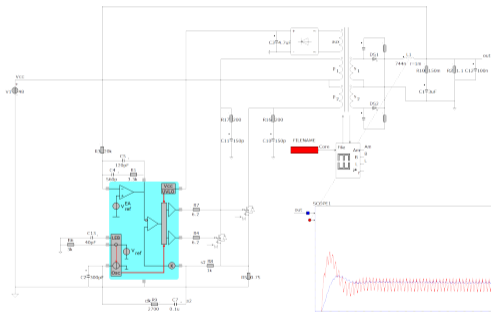

## What is Simulation?

- 1 What is the purpose
- 2 What is the problem to solve
- 3 Education

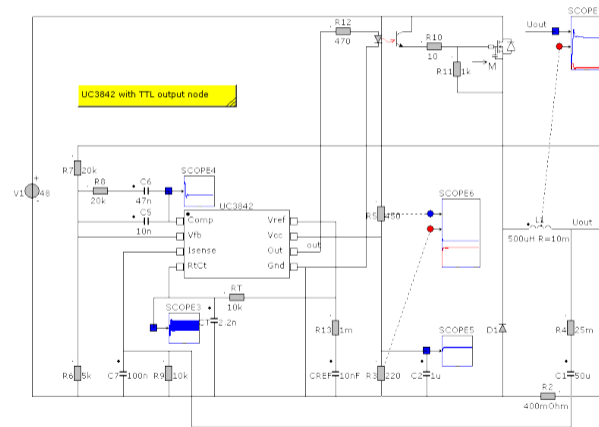

## Education &amp; Research?

- 1 Online Tool, introduction
- 2 Online Simulation, understanding
- 3 Caspoc Simulation, details

## Teaching?

- 1 Animation
- 2 Virtual Labs

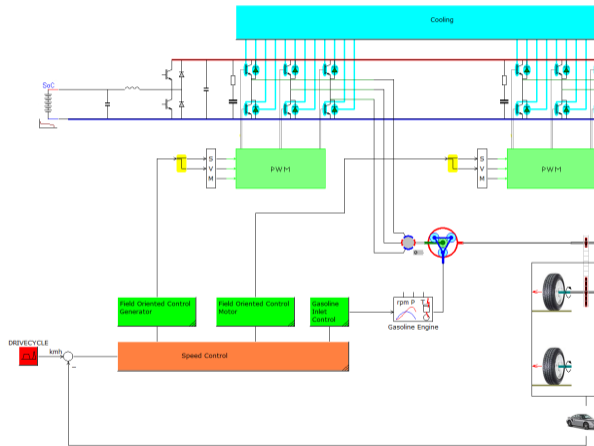

What to use the design tools for?

- ① First introduction
- ② Gain understanding
- ③ Guess for parameters

Pro & Con?

- ① Dedicated, not flexible
- ② Easy to use
- ③ Can't go wrong

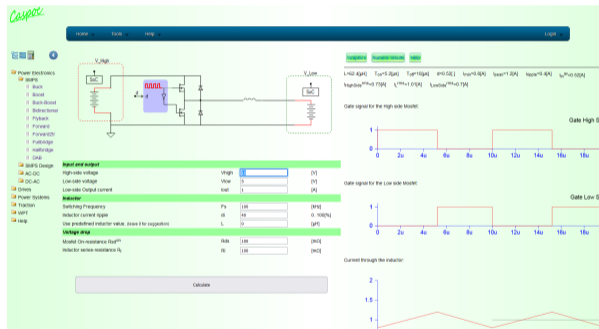

Why to use an online simulation?

- 1 Runs always!
- 2 Easy to distribute by email
- 3 Basic examples

Pro & Con?

- 1 Only small simple simulations
- 2 No installation

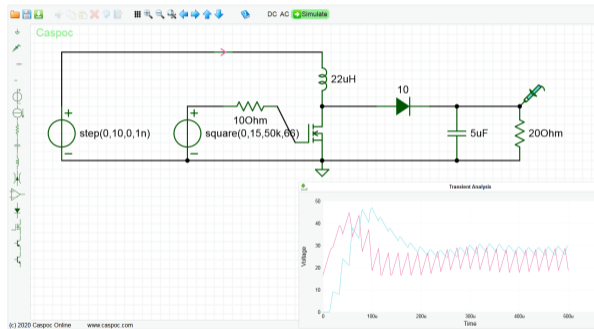

## Hierarchical

- 1 Basic
- 2 Generic
- 3 Detailed

## Extra

- 1 Thermal, EMC, Stability,....

## Methods

- 1 Animation
- 2 Freeze & GoBack
- 3 Matlab2Caspoc
- 4 Export C-code

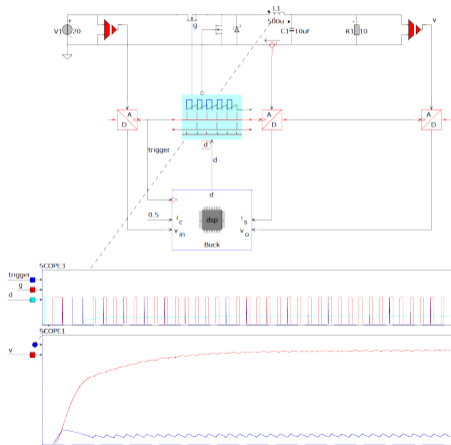

## Laboratory

- 1 Low entry level
- 2 Typical Electricity examples

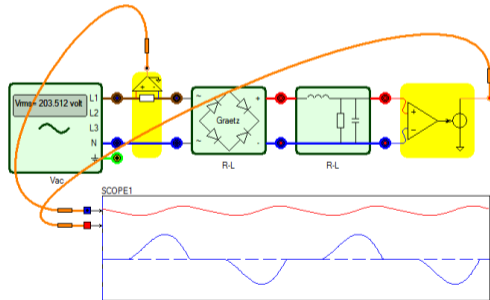

## Breadboard

- 1 Basic electronics
- 2 Prepare for laboratory

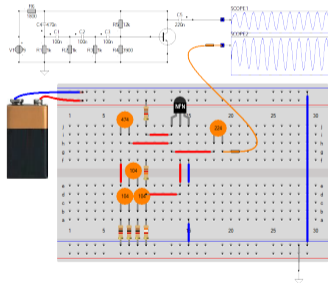



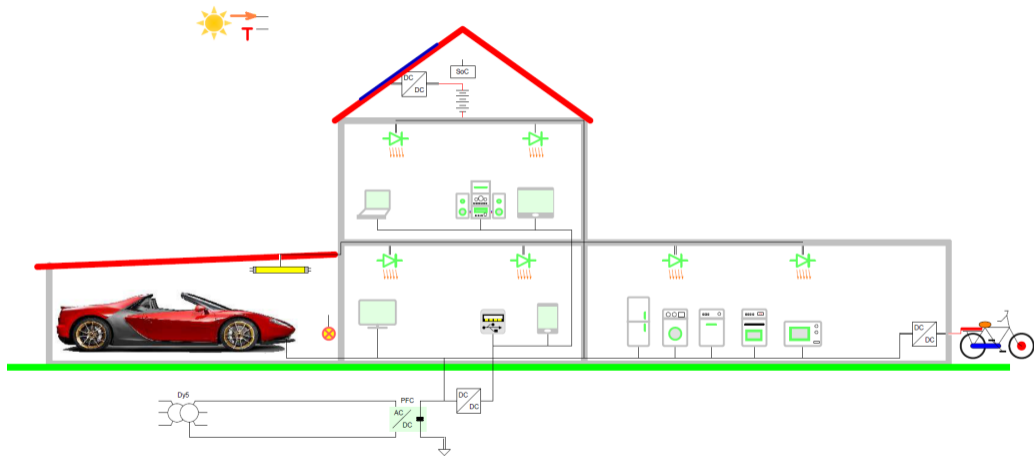

- Design Tool
- Hierarchical Simulation
- Virtual Labs

Thank you!

[www.caspoc.com](http://www.caspoc.com)

[P.vanDuijsen@caspoc.com](mailto:P.vanDuijsen@caspoc.com)

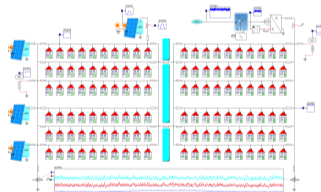

Caspoc Help: <https://www.caspoc.com/help/handson/>

Tools:<https://caspoc.com/tools/powerelectronics/smps/buck/>

Online Simulation: <http://dc-lab.org/hhs/onlinesim/>

Info on simulations I:

<http://www.dc-lab.org/presentations/Mipro2023/Mipro2023PE.pdf>

Info on simulations II:

<http://www.dc-lab.org/presentations/Mipro2023/Mipro2023EM.pdf>

Caspoc Download Viewer (for temporarily license ,please contact me via email)

[https://caspoc.com/news/workshops/renewable/Caspoc2017RII\\_Start\\_](https://caspoc.com/news/workshops/renewable/Caspoc2017RII_Start_Welcome2017exe.zip)

[Welcome2017exe.zip](https://caspoc.com/news/workshops/renewable/Caspoc2017RII_Start_Welcome2017exe.zip)