

# Droop Control in DC Grids using the Universal Four Leg as Laboratory Setup

Alexander Spaans, Diego Zuidervliet, Peter van Duijsen\* .

**Abstract:**

*Droop control is used for power management in DC grids. Based on the level of the DC grid voltage, the amount of power regulated to or from the appliance is regulated such, that power management is possible. The Universal 4 Leg is a laboratory setup for studying the functionality of a grid manager for power management. It has four independent outputs that can be regulated with pulse width modulation to control the power flow between the DC grid and for example, a rechargeable battery, solar panel or any passive load like lighting or heating.*

**Keywords:**

*DC Grid, Droop Control, Power Management, U4L, Caspoc*

*\*Corresponding Author Email: p.j.vanduijsen@hhs.nl*

## I. INTRODUCTION

DC grids are the natural choice for power distribution because renewable energy sources like solar power are easily integrated. DC grids allow power management to be implemented using power electronics.

Power management is facilitated by droop control, where the DC grid voltage is the controlling signal for the power management. Droop control functions independent of any communication, only the voltage level of the DC grid determines the amount of energy available in the DC grid.[2]

In this paper a laboratory setup is described where the basics of droop control can be implemented. The implementation in a microcontroller is performed and for a stable operation, accurate voltage measurements are required.

The Universal Four Leg (U4L)[1], is a DC grid manager with four outputs. Using the U4L it is possible to convert DC-DC, DC-AC & DC-3-Phase AC inversion. All this would be controlled by a Arduino micro controller. To make this system smart a droop control was implemented.

With likely potential of DC power becoming the standard in the future, a whole era of AC power will become less vital for us. Why are we moving forward from AC to DC while AC is widely available? While this is true, most of the devices we use right now work on DC (e.g. electric cars,

solar panels, phones, batteries). These devices work with a converter at the moment. Making it the other way around (convert DC to AC when necessary) would increase efficiency and logic in general. Besides this DC has become a more stable, safer and more adaptable/smart replacement[4][5]. With this transition DC grids or micro grids will be making its way into households and offices[4]. Giving us better control in certain problematic circumstances. For example in cases of a short circuit or power shortage, the grid manager in a DC grid can control. In both cases DC is superior to AC giving a safer and more adaptable environment to work in.

In section II the Universal 4 Leg is introduced. Droop control is discussed in section II, where the procedure for designing the droop control is outlined in section IV. Section V shows the practical setup and shows a typical measurement.

## II. UNIVERSAL FOUR LEG

A DC grid manager can be made with the Universal Four Leg (U4L)[1]. It's a compact standalone system making it possible to be implemented in smaller environments like households or offices. This system is made out of four half bridges [1] as output with a DC input range of 15-55V, see Fig. 1. By programming an Arduino Nano, a PWM-signal can be created to control the output voltage on the U4L.

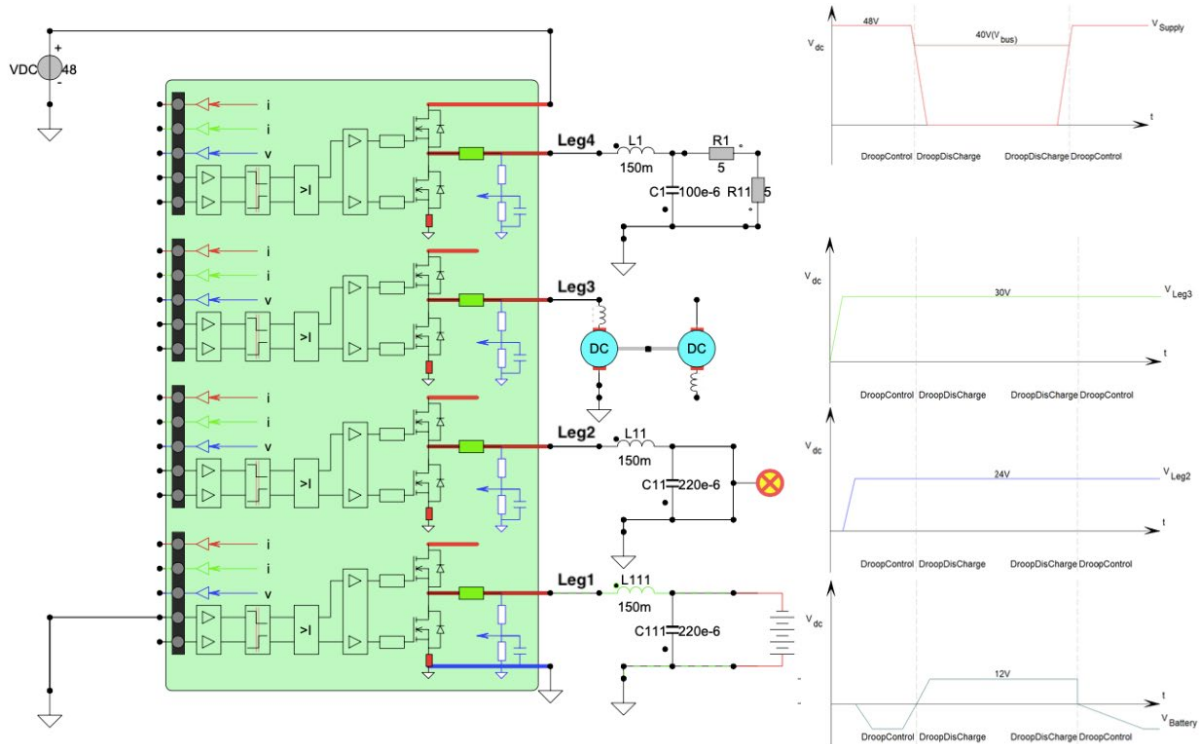

**Figure 1: U4L configured as laboratory set up power from top to bottom; Passive load, Dc motor, light and a rechargeable battery.**

Fig. 1 shows the set up used for measurements and demonstrations. During measurements most of the time a combination of the  $5\Omega/50W$  power resistors are used on a heat sink as at Leg 4. This leg will probably produce most of the power as in the final version this leg will output a pulse-width of 90% of the input voltage. For demonstration purposes we added a DC Servo motor linked to another DC Servo motor which is connected to a VDC multimeter. Both motors run on 6.4V/KRPM and during demonstrations leg 3 will most likely be set on 15V to 30V. On leg 2 a light can be found, referring to either a 25W 12v or 20W 24V Halogen light depending on the output that needs to be tested. On the first leg there is a battery connected. Just like the halogen light this is connected by the same LC network. The voltage on the output on the leg could differ between 7.4V to 14,8 depending on the battery. Or as example a power supply could be used to have more control during testing. The droop characteristics for each load are given on the right side of Fig. 1. Each leg can independently be programmed such, that given a DC grid voltage, the output power can be regulated according to that droop characteristic. This achieved by controlling

the output current of each leg independently using a pulse width modulation. To regulate the average output current, each leg is connected via a series inductor to its load.

### III. DROOP CONTROL

Even though direct current doesn't change as much as alternating current, the voltage overall can of course still change. E.g. as you have a solar panel as your main power source at home and it becomes cloudy and a few minutes later the sun comes back again. In these moments the output to your devices at home should still give you the same voltage. A droop control should be able to adjust the voltage output in such ways that it stabilizes whatsoever the input voltage is.

In other words the value of the voltage on the dc grid determines the available amount of power that can be consumed. A dc voltage above the nominal (dashed in the figures) value means there is a shortage of power and a load has to lower the consumption. While if the dc voltage is above the nominal value this mean the load can consume maximum power. An example of a droop control function for a motor can be seen in Fig.2.

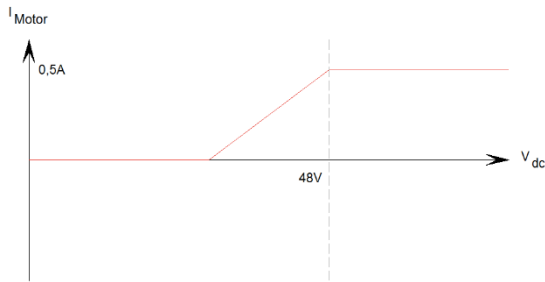

Figure 2: Droop control for a Dc motor

Another part of the droop control can be prioritization. Meaning a certain load would be more important and should stay on at all times against e.g. a light that can turn off as it's still light outside. A similar droop control would look like Fig.3.

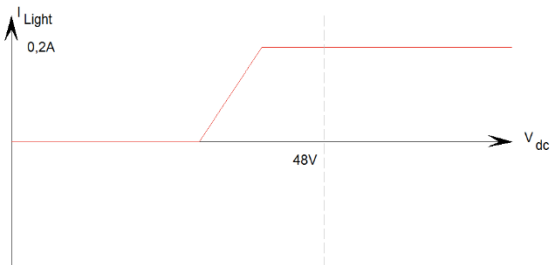

Figure 3: Droop control for lighting

Besides controlling the voltage outputs a different approach can be added. Making it possible to charge a discharge a battery so that the system and loads can still work as they're supposed to. This is shown in Fig.4.

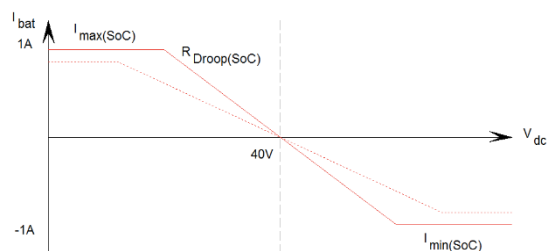

Figure 4: Droop control for a rechargeable battery

#### IV. DESIGNING THE DROOP CONTROL

Designing the droop control requires knowledge on how to configure each characteristic for each individual leg. The characteristics first have to be tested inside a design tool[3], where adjustments can be made regarding the exact position of each characteristic, see Fig. 5.



Figure 5: Designing the droop control characteristics in Caspoc design tool[3]

After the droop characteristics are known, the complete circuit can be simulated, see Fig.6. Here a dual leg grid manager is simulated with solar panel, maximum power point tracker and a battery charger[3].

The solar panel is connected to the grid manager via an inductor of 100uH. The current level in this inductor can be regulated, as it is measured in the output of leg 1 of the U4L. Using the pulse width modulation inside the U4L the averaged current is controlled according to the maximum power point tracker.

The rechargeable battery, in this case a 12V lead acid battery is connected via an inductor of 100uH. Also here the battery current is regulated by the U4L using pulse width modulation.

The amount of current that the solar panel is delivering varies with the amount of sunshine and the amount of current going in to the rechargeable battery depends on the voltage level of the battery, indicating its state of charge. The remaining current is exchanged with the DC grid. In this case the amount of solar current is higher than the battery charge current and the remaining current is delivered into the DC grid. Here the DC grid is built from four lead acid batteries. The pulse width modulation for the two legs is programmed inside the microcontroller. Here a low-cost Arduino-Nano is applied.

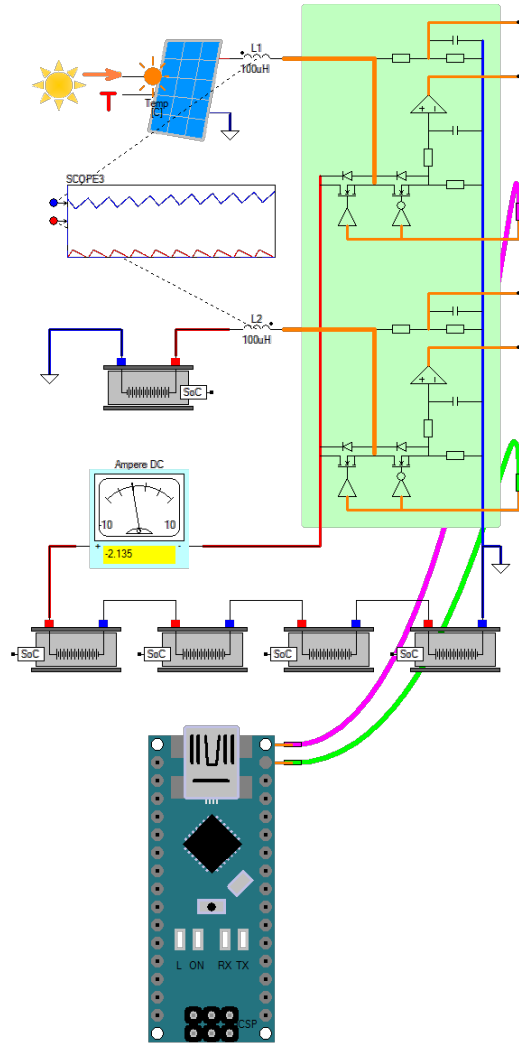

Figure 6: Simulation[3] of a grid manager with droop control and two legs. Leg 1 controls the solar panel using a build in maximum power point tracker, while leg 2 includes the droop characteristic for a rechargeable battery.

## V. IMPLEMENTATION

The implementation of the droop control into the Universal Four Leg is done by programming the droop characteristics into a microcontroller. As the Universal Four leg is adjusting the voltage output already by changing the pulse-width for each individual leg, this approach of the droop control is based around that. It will compare the voltage of the legs to the voltage set point given by the user and adjust the pulse-width until a stable output voltage is reached.

With the battery discharge function implemented in the droop control we made a semi remote droop

control regulation giving the following scope image as shown in Fig. 7.

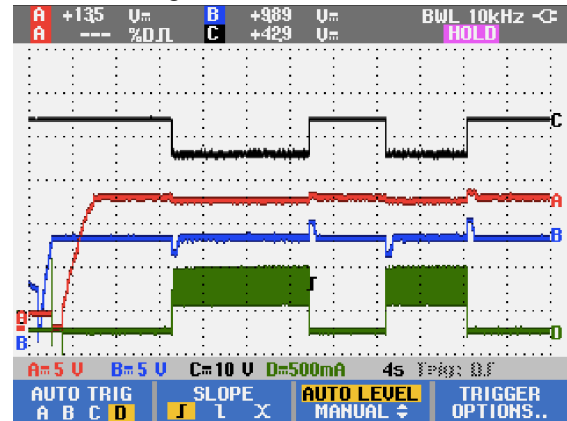

Figure 7: At 48V on the Input voltage of the U4L (Vbus), Input C, a stable pulse-width of respectively 15V & 10V on Leg one & two of the U4L at Input A & B of the scope. Input D shows the current going through Leg one/Input A.

At the start of the image of Input A & B shows the start up from a pulse-width of zero until the outputs reach the correct voltage. On leg one/Input A is a power-supply connected giving 15V through a lowpass filter. The input voltage (Vbus), Input C, drops twice showing the interception by the droop control so that the battery supplies the U4L with a stable 40V. This all while the other leg minimally changes or quickly reacts on the change happening. The response of the droop control in time is outlined in Fig. 8.

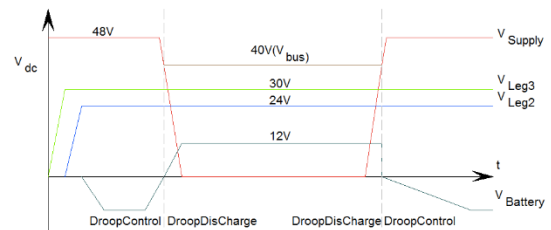

Figure 8: Droop control with Voltage drop, charge and discharge of a battery and overall stabilizing of the legs/outputs.

The laboratory setup is shown in Fig.9. Four passive loads of 10Ω can be connected to the U4L over four inductors of 100uH. In this typical set up two loads are connected and the voltage and current for the upper leg are displayed in the two multi meters. The output of the upper leg is set to 22.4V, being created from the DC grid voltage of 48V. The current through the load equals 2.2A.

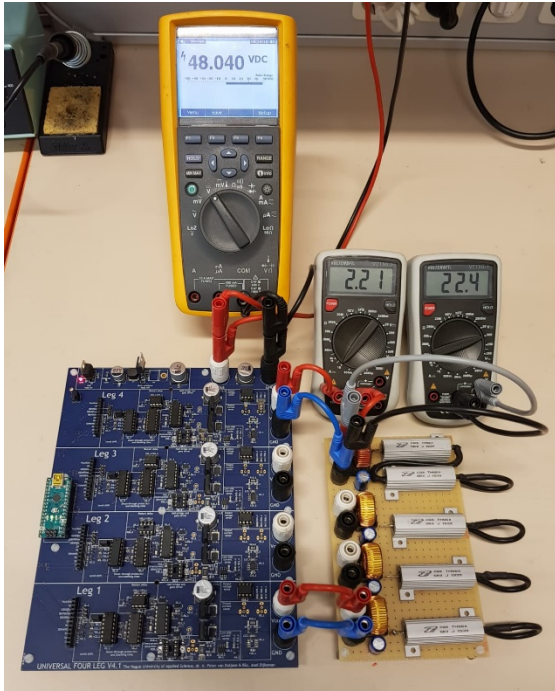

Figure 9: Laboratory setup with 4 passive loads.

## VI. CONCLUSIONS

Droop control can be implemented into a Grid Manager for a DC Grid. Using the droop control, power management can be achieved. To study the influence of each characteristic in the droop control, there are three steps that can be taken. First the characteristics are constructed in a design tool. Secondly the droop characteristics can be simulated and finally the droop control can be tested in a laboratory setup.

## REFERENCES

1. P.J. van Duijsen D.C. Zuidervliet, "DC Educational Development.Improving understanding of DC to DC / DC to AC conversion,," Sefi Proceedings, [Online]. Available: <https://www.sefi.be/wp-content/uploads/2018/10/SEFI-Proceedings-2-October-2018.pdf>.
2. P. J. van Duijsen, J. Woudstra, and D. C. Zuidervliet, "Requirements on power electronics for converting kitchen appliances from ac to dc,," 2019, [DUE 2019].
3. Caspoc, Simulation Research 2021 [Online]. Available: <https://www.caspoc.com/>
4. B. Nanhekhan, J. Woudstra and P. van Duijsen, "Brushed universal motor controller for DC-grids,," 2018 19th International Conference on Research and Education in Mechatronics (REM), 2018, pp. 153-158, doi: 10.1109/REM.2018.8421781
5. P. J. van Duijsen and D. C. Zuidervliet, "Structuring, Controlling and Protecting the DC Grid,," 2020 International Symposium on Electronics and

Telecom. (ISETC), 2020, pp. 1-4, doi: 10.1109/ISETC50328.2020.9301065.

## ACKNOWLEDGEMENT

The authors would like to thank Ruan de Jonge and Nathan Swanepoel for their help in designing the MPP and programming the U4L-Nano.

## Author Biographical Statements



Alexander Spaans, 1996 The Hague, followed his high school at the Chr. gymnasium Sorghvliet and is as of now studying electrical engineering at The Hague university of Applied Sciences..



Diëgo Zuidervliet holds a Bachelor degree in Electrical Engineering from The Hague University of Applied Sciences THUAS in Delft, The Netherlands. He is a researcher at the THUAS DC-Lab. His research field is power electronics and DC grids and specializes in control and protection of DC grids using power electronics.



Prof. Dr. Peter van Duijsen [Prof. of Practice, IIT Guwahati, India] After receiving his Masters in Electrical Engineering, he founded Simulation Research and developed the simulation program CASPOC. He received a PhD degree in 2003 in the field of Modeling and Simulation of Power Electronic Systems From the TU Delft. Currently he heads the research and development department at Simulation Research. Since 2020 part-time Researcher at the DC-LAB at the THUAS University of Applied Sciences in Delft, The Netherlands and appointed as Professor oP at the IIT-Guwahati-India since 2020.